

VINTAGEVIEW

DESIGN
2021



WE DESIGN

It started with a simple idea: Bottles of wine should be easy to find in a wine cellar. We figured it'd be better to store them with the labels facing out.

It blossomed into a movement.

When we first invented the (now patented) label-forward wine rack in 2001, it sent us on a journey with the professional design/build community that moved wine cellars from back basement corners and into the forefront of commercial and residential design.

Our products have continued to push the envelope for transforming wine displays into architectural features that are every bit as practical as beautiful.

Couple that with our superior quality and service, there's a reason we continue to be the most trusted wine rack design firm for talented building professionals and creative DIYers alike.

[VINTAGEVIEW.COM/2021](https://vintageview.com/2021)

Table of Contents

4	24	36	46
Residential	Hospitality	Retail	Resource

On the Cover: The New American Remodel 2021; see page 12 for details

On the Back Cover: Cellar by Kasper Custom Remodeling. Location: Dallas, TX. Wine Display: W Series Wine Racks, matte black finish, 792 bottles



Photo: Micheal McNamara/ZenHouse Collective
Location: Studio City, CA

 Wine Display: W Series Wine Racks, matte black finish, 63 bottles



@vintageview_usa



@VintageView



@Pro/VintageView



Scan for BILT 3D
Instructions

THE RESIDENTIAL AESTHETIC

versatile racks
for your space

The wine cellar is hardly reserved for just the serious collector. In fact, the modern wine cellar isn't just a cellar anymore, either.

VintageView's cutting edge wine racking products have transformed wine storage into versatile architectural features that start at just a few bottles in wet bar designs and range to tens of thousands in expansive collector basements.

Explore the versatility in the pages that follow to get an idea of how our simple, refined products create the custom wine display results demanded by top building professionals and discerning do-it-yourselfers.

Design: Dream Homes by Scott Living

Location: Las Vegas, NV

 **Wine Display:** Evolution Wine Wall Post System,
chrome/matte black finishes, 576 bottles



DESIGNERS TOUCH

Sandy Horwitz
Innovative Wine Cellar Designs

If you want to know where the wine display industry has been and where it's heading, there are few professionals with better insight than Sandy Horwitz, owner of Innovative Wine Cellar Designs (an elite VintageView design partner) in Scottsdale, AZ.

By his estimation, he has built more than 3,000 wine cellars since he opened in 2002. Residential, commercial, big, small. He's seen — and designed — it all.



VintageView: Where do you draw inspiration for wine cellar design?
Sandy Horwitz: I get a lot of inspiration from architectural buildings and from high-end boutiques. Every time I look at a store, I see all these cool displays and wonder, “how can I integrate that into a wine cellar?”

VV: Your design style in five words:
SH: Functional. Contemporary. Artistic. Sleek. Relaxed.

VV: What does “relaxed” mean for you in design?
SH: People just feel a calm. They feel relaxed and enjoy it like a piece of art. So many people tell us when we are done, they look at it as a piece of art. They can sit there for hours and enjoy it.

VV: COVID question: What is changing about cellars in 2021?
SH: People have been locked down, spending time in their homes. Now that they are spending more time there, they are thinking, “what can we do to make it better?” Many are deciding on wine cellars.

VV: Any design differences because clients might not be entertaining guests at the moment?
SH: They have that collection, and they want to show it off. It still becomes a focal point of the house, and they know at some point they will entertain again.

In terms of look: It's still the emphasis on the contemporary wine walls. We are designing most with LEDs and using mostly metal and acrylics as our materials. A lot of what we are doing now — and what we'll continue to do — is incorporating liquor collections.

VV: Your favorite wine room featuring VintageView racking?
SH: Tanzy (restaurant in Scottsdale, flip to page 31). That was really cool. Thirteen feet tall. Stunning. For homes, “Bottoms Up” (page 16). It's right in the front doorway. We rotated the W Series Frames 90 degrees to have the butts of the bottles facing the entrance. Really creative look. It's just so different.

VV: Finally, your go-to wine.
SH: I go to spirits more often. Usually a lemon drop martini.
VV: Fair.

We have VintageView Elite Partners like Sandy throughout North America. Let's find the right one to work with you! vintageview.com/2021

COSTA DEL SOL

An oversized, framed glass door sets an impressive tone for a beautiful wine room that is a standout in this “Fort Worth Magazine Home of Dreams 2018” project. We'll be dreaming of this for quite some time.



Design: PentaVia Custom Homes
Location: Westlake, TX
Wine Display: W Series Wine Racks, W Series Frames, matte black finish, 384 bottles



ELLISON AVENUE

The art of the wine display often lies in restraint. This entertaining lounge pulls aficionados in with a seductive color palette, oversized chairs, and a tidy backlit wine display.



CENTURY FARMS

Creating a model home takes resolve. The perfection sought can be the difference maker in how well (and quickly) potential residents reserve properties in the community. With rooms like this, it's safe to assume that the homes in Century Farms are a hot commodity — and glass wine rooms a frequent custom upgrade request.

Design: Bickimer Homes
Location: Overland Park, KS
Wine Display: W Series Wine Racks, matte black finish, 90 bottles



Design: Fe Fi Faux Studios
Location: Omaha, NE
Photography: Sandra Lassley
Wine Display: Evolution Wine Rods, custom cut; matte black finish; 20 bottles



MAKING A CASE

Attention to detail is shown in every inch of this concept room. The glass wine room makes the statement that this room is all about entertaining — with wine open — whether it be inside in those stylish dining chairs or outside in a beautiful backyard.

Design: Wine Cellars Inc.
Rendering: Wine Cellars Inc.
Wine Display: Case & Crate Bins, W Series Wine Racks, matte black finish, 390 bottles



THE NEW AMERICAN STYLE

Each year, two top building firms each tackle a unique residential project that brings together the most advanced design practices, products, and more as part of The New American Home & Remodel showhomes.

The luxe properties become the must see exhibits of The International Builder's Show, with thousands of attendees hopping on shuttles away from the convention center to explore the gorgeous residences. **One a new build, one a remodel, both stunning.**

This year, the projects debuted in Orlando in February 2021. While the pandemic closed the in-person tours, it opened the door for us all to view them through engaging HGTV-style video and great photography.



Read on for more of these projects, then click over to

vintageview.com/SHOWHOMES21

to get a more intimate look.

“When designing the bar, we wanted it to be as central as possible because the bar is always at the heart of entertaining.”

Phil Kean, Phil Kean Design Group



The remodel turned a 1973 home into a bold, 7,200-square foot lakeside abode with hints of Frank Lloyd Wright throughout. **The wine feature is elevated** from a formal sitting area to give it maximum connectivity to those over for a bottle. It maxes bottle capacity with floating wine walls and our innovative Bin storage system. Frameless glass, a stunning stone backsplash, and a few Perches add the final design enhancements.



This home flips the living space upside down, literally. With the main entertaining zone on the third floor and the bedrooms below, this Phil Keane space elevates the townhome and packs a lot into 5,500 square feet. The top floor is made for the type of person who wants to invite friends over to enjoy a great glass of wine inside or out. The wet bar features a **simply elegant 22-bottle wine display** with VintageView's new Flex rack — in stunning golden bronze.

Designer: Phil Kean Design Group

Location: Winter Park, FL

Photos: Jeffery Davis

 **Wine Display:** Vino Pins Flex, golden bronze finish, 22 bottles



“VintageView’s racking completed the vision of including a wine detail and helped blend two distinct spaces together for a spectacular feature.”

Rob Smith, E2 Homes

Designer: E2 Homes

Location: Orlando, FL

Photos: Jeffery Davis

 **Wine Display:** Evolution Wine Wall Post System, Case & Crate Wine Bin, matte black and chrome finishes, 415 bottles

OTSEGO STREET

A little wine goes a long way, especially when the bottle storage is designed this well. This clever use of space features a clean display, behind glass, that can fit six cases of wine. With such a visual footprint in this home, the most difficult task will be keeping the racks stocked.



Long Lasso Pass, Leander, TX
Design: VintageView
Wine Display: Vino Pins, W Series Wine Racks, matte black finish, 147 bottles

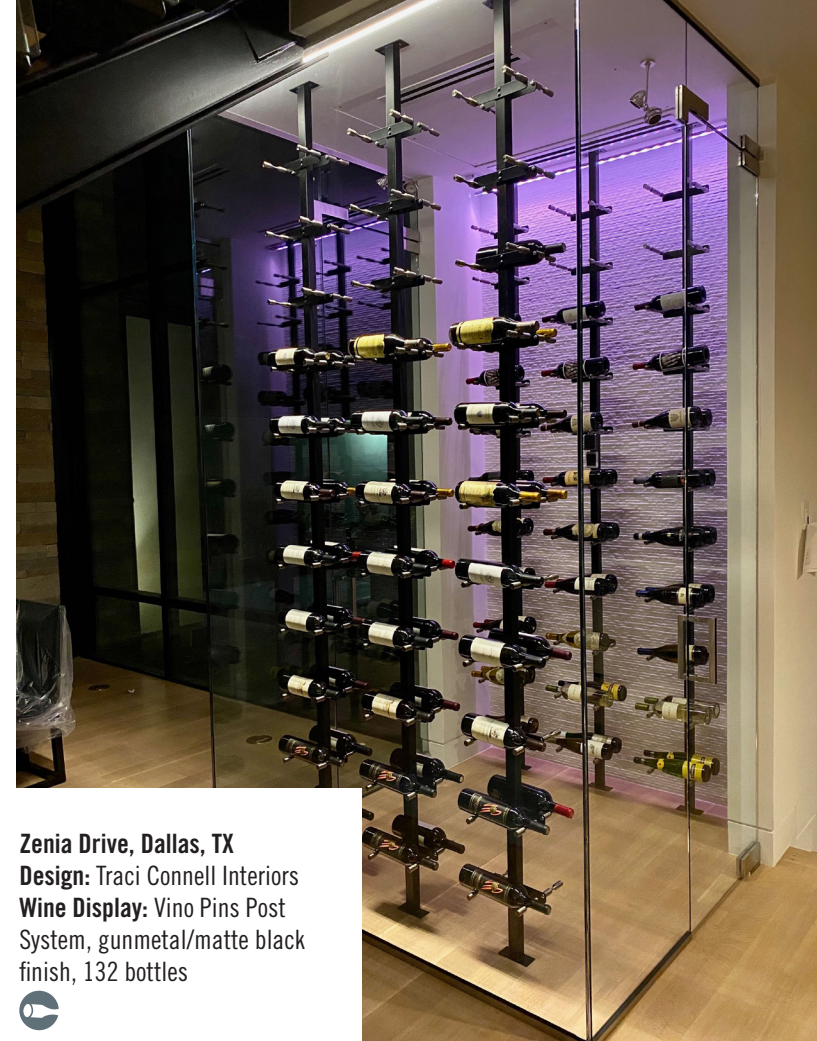

Zenia Drive, Dallas, TX
Design: Traci Connell Interiors
Wine Display: Vino Pins Post System, gunmetal/matte black finish, 132 bottles



Turney Wine Room, Oklahoma City, OK
Design: VintageView.
Wine Display: W Series Wine Racks, Vino Pins, matte black and milled aluminum finishes, 452 bottles

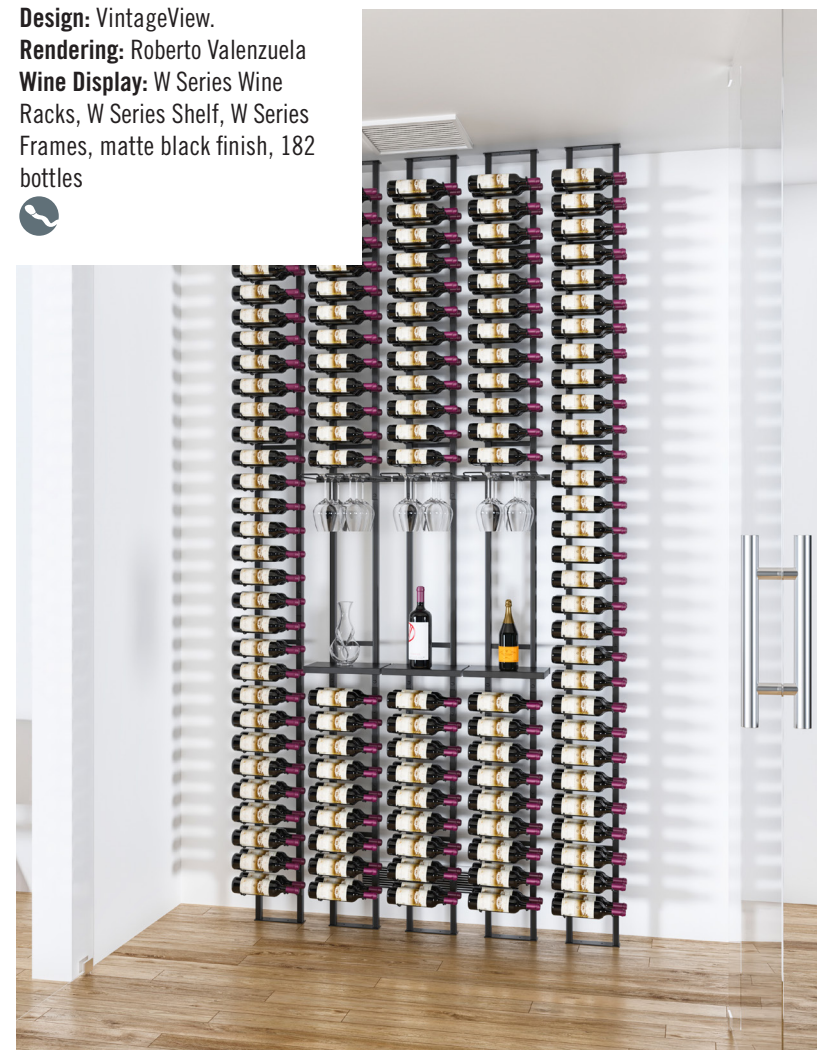

Design: VintageView.
Rendering: Roberto Valenzuela
Wine Display: W Series Wine Racks, W Series Shelf, W Series Frames, matte black finish, 182 bottles



Location: Sherman Oaks, CA
Photographer: Michael McNamara/ZenHouse Collective.
Wine Display: W Series Wine Racks, matte black finish, 72 bottles

BOTTOMS UP

Turn our innovative wine racking 90 degrees and *this* happens. An interesting take on traditional style of cork-forward wine racking that creates bold sidelines at the entrance of this Scottsdale home. We should all be so lucky to have Sandy (flip to page 6) from Innovative Wine Cellar Designs create our wine features.



Design: Innovative Wine Cellar Designs
Location: Scottsdale, AZ

 **Wine Display:** W Series Wine Racks, W Series Frames, brushed nickel finish, 780 bottles



GOLDEN DINING

A formal dining room deserves careful thought in regards to the different pieces of hardware included in the concept. Ensuring the wine wall looks good against a backdrop that features a dominant focal point, such as a high-end chandelier, is of utmost importance. VintageView's diverse finish offerings allow top design firms to properly match colors. In this case, golden bronze, one of the most popular finishes of the year.



IN LINE

They say stripes are slimming. We think this holds for interiors as well as apparel. VintageView's latest mounting system for our popular Vino Series, Flex, makes a bold, cork-forward style statement in this living room. What are we pulling off the wall tonight?

Design: VintageView

Rendering: Roberto Valenzuela

Wine Display: Vino Rails Flex System, golden bronze finish, 36 bottles

Design: VintageView

Rendering: Roberto Valenzuela

Wine Display: Evolution Wine Wall, matte black/golden bronze finish, 432 bottles



Seville Cove, Westlake, TX.
Design: PentaVia Custom Homes
Wine Display: W Series Wine Racks, W Series Frames, matte black finish, 288 bottles



Weather Vane Drive, Troy, MI
Design: MCCS: A Design Build Firm
Wine Display: Evolution Wine Tower (custom), W Series, acrylic and matte black finishes, 212 bottles



Stonebluff Lane, Noblesville, IN
Design: VintageView
Wine Display: Evolution Wine Wall, matte black finish, 270 bottles



St. Jude Dream Home, St. Louis, MO
Design: Lamp Wine Cellars & Payne Family Homes
Wine Display: Vino Pins Post System, gunmetal finish, 160 bottles

HEAD OF POND ROAD

We are not sure what steals the show in this dining room: the sexy wine wall or the incredible chairs by Phillips Collection. We don't think it matters. This room is begging for lavish dinner parties. Bravo to designer Elsa Soyars on this tony room in the Hamptons.



Design: Elsa Soyars Interiors
Location: Water Mill, NY
Photographer: Bob Frame Studio
Wine Display: Vino Pins, milled aluminum finish, 162 bottles

LONGWOOD DRIVE

What's for dinner? Doesn't really matter as much when you have access to so many bottles of wine within reach of the dining room table. We can imagine intimate culinary feasts in this fabulous room designed by Julie G Studio, however. What bottle would you reach for first?



Design: Julie Geyer Studio
Architect: Carmel Greer
Photographer: Jenn Verrier
Location: Bethesda, MD
Wine Display:  Vino Pins, gloss black finish, 193 bottles

HOSPITALITY MINDED DESIGN

simple wine walls,
bold statements

Creating engaging wine features on dining room floors has become one of the most important trends in hospitality today.

These gorgeous displays not only look great and serve as practical storage for service staff, but they can also break down the mystery of voluminous wine lists. The labels beg guests to engage. And order.

We find using visible wine displays one of the best ways to improve the guest experience and encourage them to explore the wine list a little bit more.

Explore the versatility VintageView offers in the pages that follow to get an idea how our simple, elegant products define experience in the modern restaurant.

A Note About COVID

The global pandemic has hurt our partners in the hospitality industry particularly hard. We are optimistic for a rebound in 2021 and hope to celebrate back out at some of the beautiful restaurants featured on these pages. Help out by ordering takeout, dining out safely if your region allows, and buying gift cards if you can. #smallbizlove



Design: VintageView

Rendering: Roberto Valenzuela



Wine Display: Evolution Wine Wall Post System, matte black/chrome finish, 648 bottles

BOURBON & BONES

Even with bourbon on the mind, this wine display steals the show. Designer Innovative Wine Cellar Designs creates an understated storage space for the hundreds of bottles that ensures diners have a difficult task in picking between the vino or “the bourbon” to pair with “the bones.”

Design: Innovative Wine Cellar Designs

Location: Scottsdale, AZ

Wine Display: W Series Wine Racks, W Series Frames, matte black finish, 648 bottles



HEXX KITCHEN

Standing out on the Las Vegas Strip is paramount to the success of amazing restaurants in Vegas. HEXX lures diners with wine on the mind, by putting label forward racking on display in front of the thousands who pass by the glass front every day (hour!?!). Great bottle of vino and charcuterie?

That's the Vegas we love.

Design: TAL Studio

Photographer: Las Vegas, NV

Wine Display: W Series Wine Racks, W Series Frames, matte black finish, 504 bottles

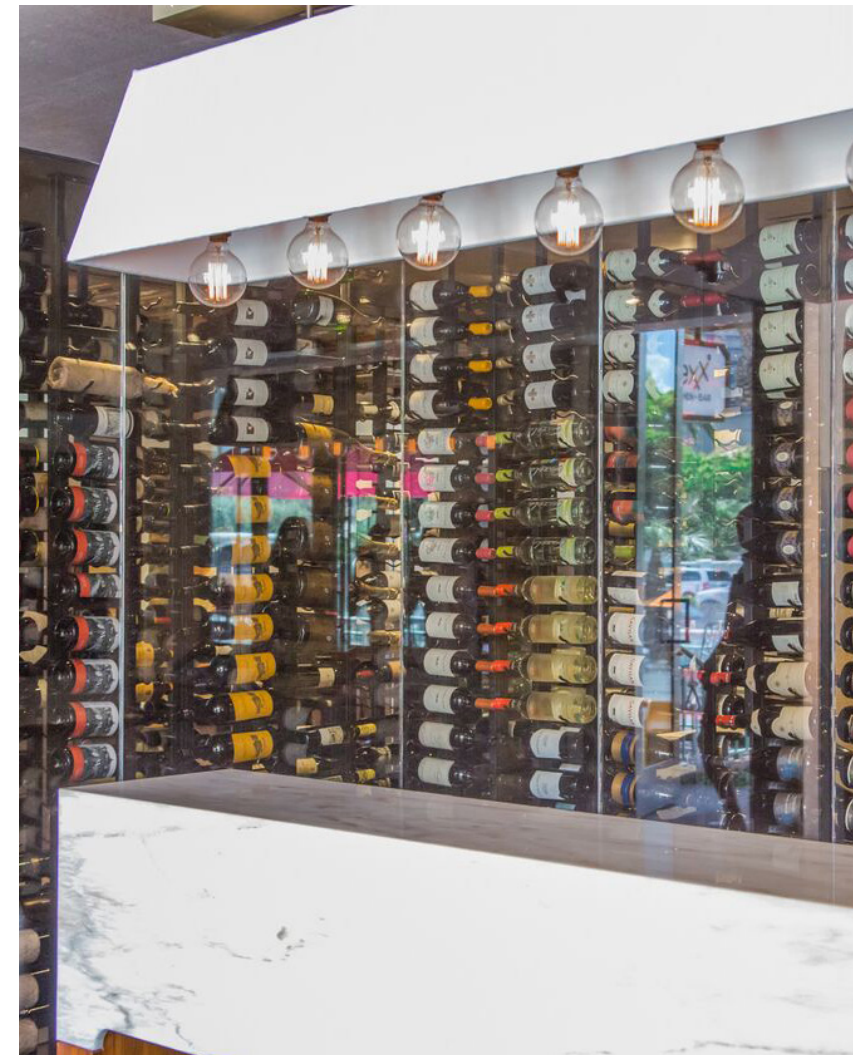

VINTAGE APPROACH

Chris Noel
Vintage Cellars

For more than two decades, Vintage Cellars has been a powerhouse wine cellar design firm serving the Southern California market, creating gorgeous displays in high-end real estate and commercial properties like Marina Kitchen (San Diego), Del Frisco's (Chicago), and 71 Above (L.A.).

We caught up with seasoned wine cellar design pro Christopher Noel, the new owner of Vintage Cellars — a VintageView Elite Wine Cellar Builder. Here's what he had to say about the industry, his process, trends, and more...

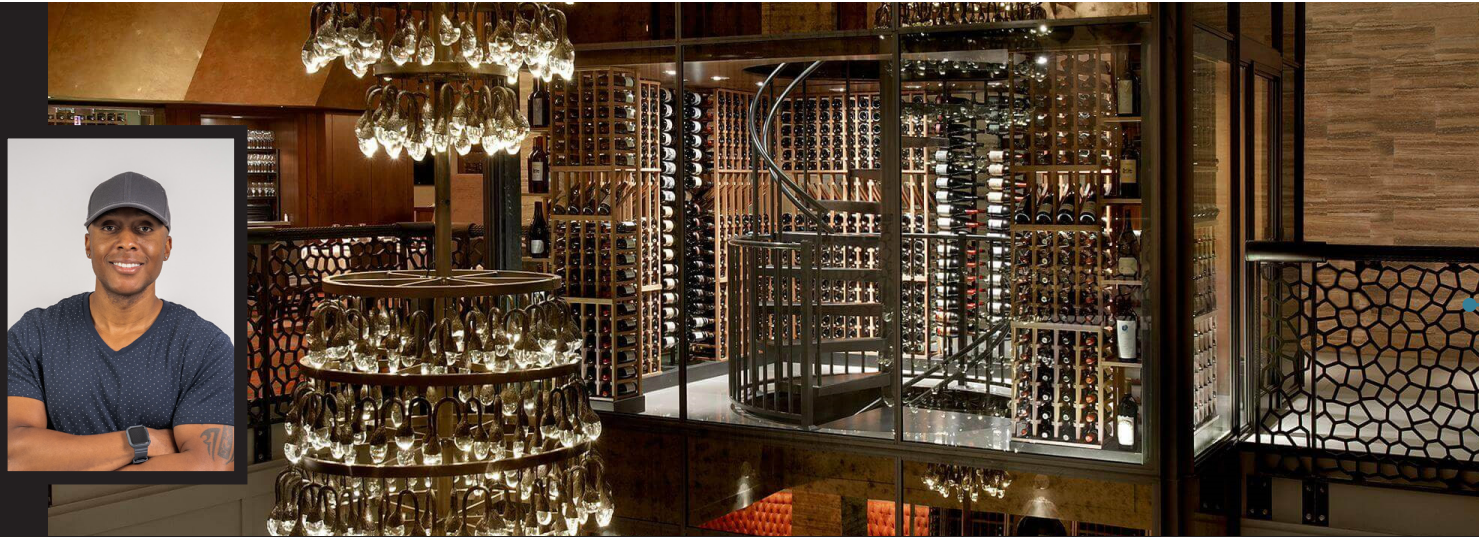

VV: Describe your process working with a restaurant on its wine cellar...

CN: Our first part of it is listening to the client's needs. We need to figure out what they want and then we can turn those ideas into a design. It's just collaboration with the designer or with the architect.

VV: What is the importance of a visual wine display at a restaurant?

CN: It's one of the most important elements of a restaurant, especially if it's a steak house or any type of restaurant where their food is meant to pair with wine. Being able to display the wine cellar just makes the experience so much more awesome.

VV: What is going to happen in hospitality design as we recover from COVID?

CN: I am not sure what to predict in terms of design changes, but here's what I would advise: Invest now. Heavily. Invest on the experience. Once all of this is over, it's going to be insane. People are going to be going out and enjoying wine, other people, camaraderie.

VV: Do you take a different approach between your hospitality and residential projects?

CN: It's very similar. We're still working with high-end designers and architects, and we are still thinking about functionally first. How do you do mechanical well, and how can we design well around that.

VV: You have plenty to pick from, but name the favorite restaurant project you've worked on?

CN: The four-story wine tower at Del Frisco's in Chicago. It's just an awesome looking wine tower. We spent over a year and half on just how to cool this all-glass wine tower. That's one of the coolest jobs I've been a part of.

VV: Okay, your go-to food and wine pairing?

CN: My go-to food is pasta or southern cooking, I love to cook and enjoy opening a fine bottle of wine to accommodate it; Zins, Viognier, and pungent cheeses on a sunny day can never be a mistake.

CUVEE 30A

It's not hard to fall for this gem along the Emerald Coast of Florida headed by celebrity chef Tim Creehan. The food. The experience. The bold wine cellar that extends into the main dining room like a cruise ship docking. Bold curved glass walls mix with VintageView's metal wine racking and custom millwork to create the type of wine cellar restaurateurs — and homeowners — dream of owning.



Design: Mark Knauer

Location: Rosemary Beach, FL

Wine Display: W Series Wine Racks, W Series Frames, brushed nickel finish, 504 bottles

We have VintageView Elite Partners like Chris throughout North America. Let's find the right one to work with you! vintageview.com/2021



SEPIA

Warm, inviting, and stylish. From the traditional hand-crafted millwork to the modern, label-forward wine display, Sepia's classic interior is the perfect backdrop to the inventive American cuisine showcased on the menu. The Fulton River District is thankful for this gem.



Design: Meyer Davis
Location: Chicago, IL
Wine Display: W Series Wine Racks, W Series Frames, brushed nickel finish, 192 bottles



Tanzy Restaurant, Scottsdale, AZ
Design: Innovative Wine Cellar Designs
Wine Display: W Series Wine Racks, W Series Frames, brushed nickel finish, 2,380 bottles



Shelve It, Concept Room
Design: VintageView
Wine Display: W Series Wine Racks, W Series Shelves, matte black finish, 414 bottles



Statement Lockers, Concept Cellar
Design: VintageView
Wine Display: Case & Crate Lockers, matte black finish, 1,150 bottles

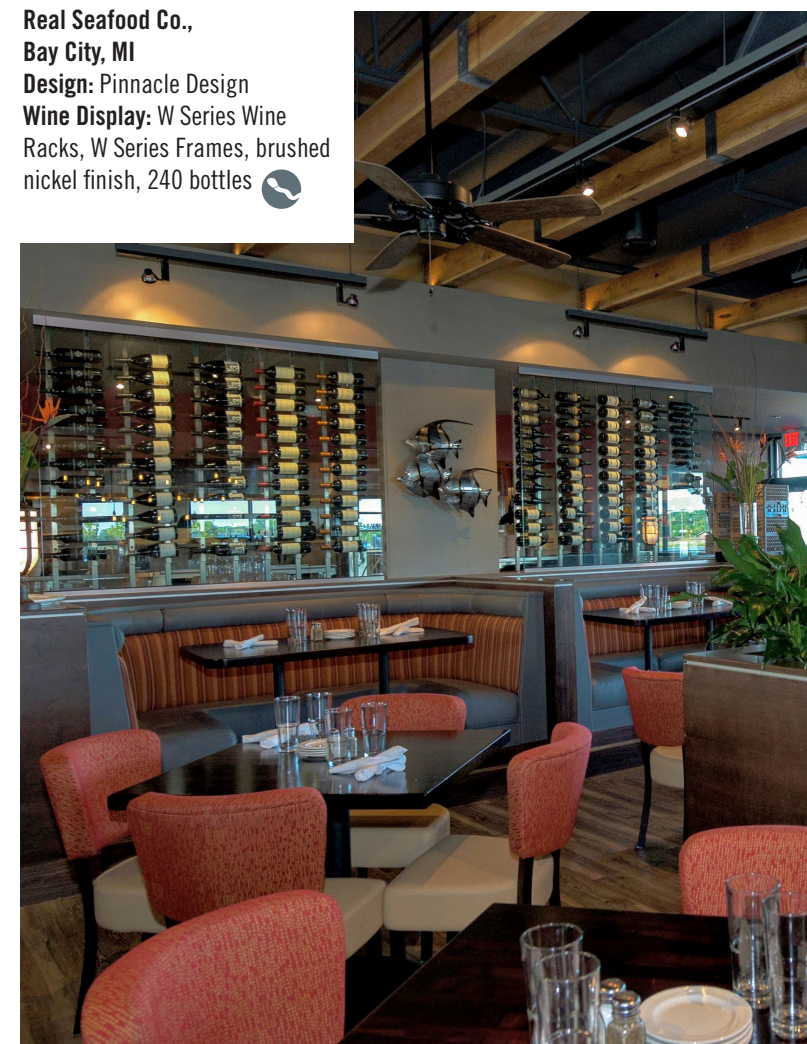

Real Seafood Co., Bay City, MI
Design: Pinnacle Design
Wine Display: W Series Wine Racks, W Series Frames, brushed nickel finish, 240 bottles



FIRE AT ART HOTEL

When a hotel sits in the middle of a city's arts district, the expectation for the interior to match the beauty nearby is high. Fire at The Art Hotel exceeds expectations. The dining room features floor-to-ceiling windows overlooking downtown Denver and a beautiful slim wine feature that sections off the eating area from the rest of the hotel. Just need passes to the next Monet exhibit at the Denver Art Museum.

Design: Davis Partnership Architects

Location: Denver, CO

Photographer: Dustin Bradford

Wine Display: W Series Wine Racks, W Series Frames, brushed nickel finish, 320 bottles

REMINGTON'S

In the heart of Chicago's Millennium Park, this sleek restaurant is the perfect spot to sip on a cocktail or glass of wine. But it will be wine on the mind of guests as this stunning wine display dominates as the architectural feature point as they arrive. Serves double duty in creating a private dining space, too. Win-win.



Design: Mark Knauer
Location: Chicago, IL
Wine Display: W Series Wine Racks, W Series Frames, brushed nickel finish, 576 bottles

YOU THINK WE'D STOP AT JUST LABEL FORWARD?

VintageView changed the wine cellar design world with its innovative, patented label-forward design in 2001. We never stop creating bold new products. Here's what's new since the last catalog dropped (and we debuted the patent pending Vino Series Post System that you love so much).



June | Universal Bottle Retention Straps



July | Case & Crate 2.0



August | Evolution Wine Rods in Golden Bronze



September | Vino Series Flex



September | W Series Perch Magnum

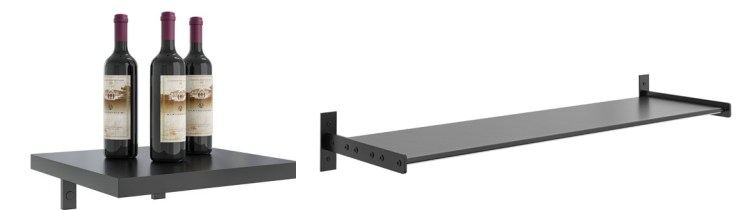

December | Shelves for W Series and Evolution Wine Wall



Coming Soon | Case & Crate Bin 1 & Locker 1



January (2021) | W Series in New Luxe Colors

RETAIL CHIC

standing out with
thoughtful layout

Gone are the days that the retail environment can focus solely on practicality. Leading retailers — from boutique wine shops to vineyard tasting rooms — are figuring out that display-oriented wine racking improves interaction between beautiful labels and the customers who may purchase them.

VintageView's freestanding Island Display Racks serve as the preferred aesthetic upgrade to create beautiful aisles to roam. When coupled with another stylish VintageView display rack option, the design options are limitless.

Flip the pages to see how top wine producers and respected retailers integrate VintageView to enhance the customer experience.



STOCKED TO ENTICE

Wine stores short on space often look for ways to pack more selections into tight aisles. The Island Display Rack 7 does the trick in this concept retail floor, creating tall wine walls that showcase hundreds of bottles without the need for a, well, wall to hold them. This balanced approach to design ramps up bottle count and doesn't take away from the visual flow of the space.



STEWART'S WINE & SPIRITS

This boutique in southwestern Connecticut elevates its wine section by putting the labels in front of customers with VintageView. The freestanding wine racks serve a dual purpose of creating great-looking aisles for customers to explore as they meander the shop. Even on the small scale, Stewart's sets the example of how to highlight wine when finite space must be balanced between a robust liquor, beer, and wine selection.



Design: VintageView

Rendering: Roberto Valenzuela

Wine Display: Island Display Racks, W Series Wine Racks, brushed nickel and matte black finishes, 3,018 bottles

Retailer: Stewart's Wine & Spirits

Location: New Canon, CT

Wine Display: Island Display Racks, matte black finish, 3,276 bottles



**Vic's Liquor
Stamford, CT**
Wine Display: Island Display
Racks, matte black finish,
1,404 bottles



Wine Legend, Brooklyn, NY.
Wine Display: Evolution Wine
Tower, acrylic/chrome finish,
1,000 bottles



HIGHLANDS WINE SELLER

Just south of VintageView HQ, the communities of Highlands Ranch and Littleton are serviced by this boutique wine merchant that spent as much time crafting its inventory as it did laying out the retail floor. Here, Island Display Racks in our tallest configurations create stop-worthy aisles of wine. Our W Series racks fit perfectly into custom wooden cubbies, and the W Series Frames are put to use under shelving, too. Great capacity and an even better experience for local oenophiles.



**Design: VintageView
Rendering: Roberto Valenzuela**
Wine Display: Island Display
Racks, W Series Wine Racks, Case
& Crate, Matte Black finish, 1,245
bottles

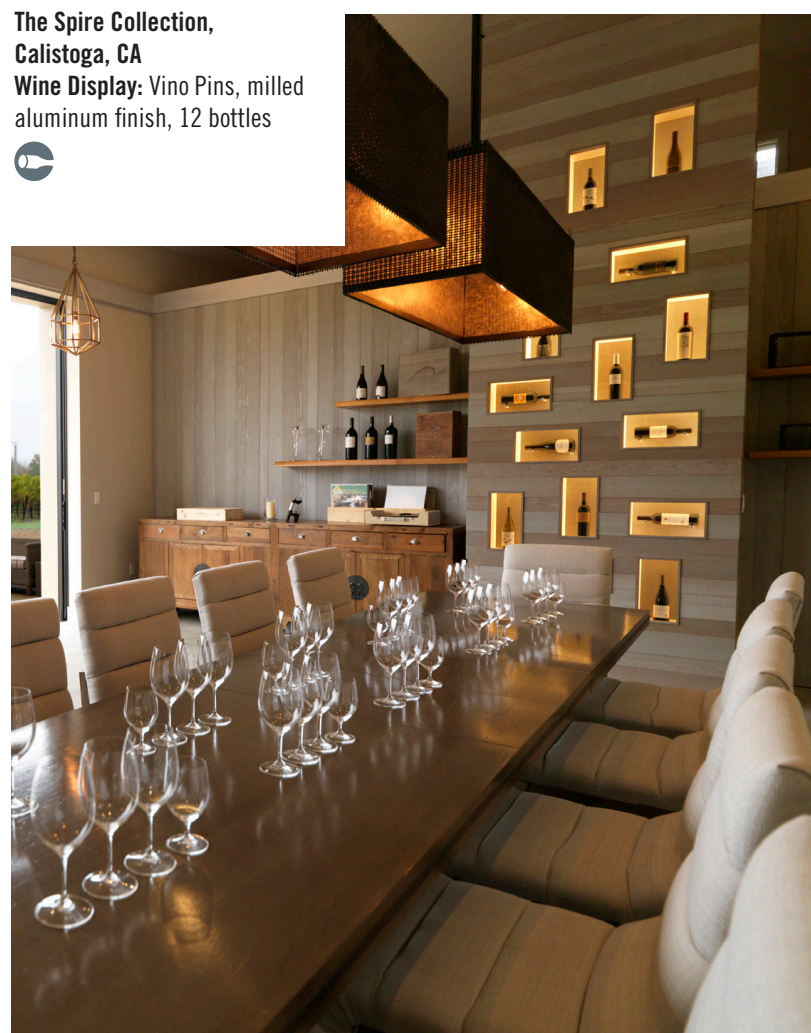

**The Spire Collection,
Calistoga, CA**
Wine Display: Vino Pins, milled
aluminum finish, 12 bottles



Location: Highlands Ranch, CO
Wine Display: Island Display Racks, IDR Point of Purchase, W Series Wine Racks, W Series Frames, brushed nickel finish, 1,000+ bottles



INVESTING IN DESIGN

Marc LeBlanc
Liquor Lodge (Jasper, AB, CA)

When photos of Liquor Lodge hit our Instagram feed, it stopped us in our tracks. The images showed such careful design consideration in a retail environment, focusing as much on the aesthetics as the wine selection itself. When we later found out this Jasper, Alberta (CA), liquor store used a bespoke interior design firm, Laurie Griffiths Interior Design, to pull off the look, we had to learn more.

We got the chance to sit down with Marc LeBlanc, founder and CEO, to discuss his business. Here's what he had to say on why it's worth investing in designer wine racks, how to make re-stocking easier, and his favorite food and wine pairing.

VintageView: How did Liquor Lodge get its start?

Marc LeBlanc: I have a passion for sharing my love of great beverages and encouraging others to drink well. We started Liquor Lodge from humble beginnings in 2007 and with the help of my wife, Megan, it has evolved into an award-winning boutique.

VV: Why did you decide to use Laurie Griffiths Interior Design to lay out your liquor boutique?

ML: A talented designer sees the things you would not and has a professional skill to design spaces to suit your needs. Choosing not to use a designer is a common mistake and is more expensive than using one.

VV: It's common for liquor retailers to go the cheaper route with shelving rather than upgrade to racking like ours. Why did you decide to use VintageView?

ML: VintageView racking meets our needs for quality and sets us apart in the marketplace. Cheaper is not our way. Better is always our first choice.

VV: What's your favorite wine and food pairing?

ML: I love French food and wine together. Coq Au Vin and 1er Cru Burgundy.



Design: Laurie Griffiths Interior Design
Location: Liquor Lodge, Jasper (AB)
Photographer: Tracey Jazmin
Wine Display: Island Display Racks, W Series Wine Racks, matte black finish, 4,035 bottles



SOCIAL WINES

Social is more than a name, it's the way in which this boutique connects with wine lovers in its South Boston neighborhood. To be "social," it engages with tastings, knowledge, value, and design. Social uses VintageView for the latter. Very well, we might add.

Location: South Boston, MA
Wine Display: Island Display Racks with Shelf Brackets, matte black finish, 2,100 bottles

MEDLOCK AMES WINERY

This old gas station in the heart of Sonoma wine country certainly received a nice second life as tasting home for this sustainable, organic wine label. Medlock Ames enlisted heralded San Francisco design firm Will Wick to ensure the transformation was every bit as crafted as the wines they pour.

Design: Will Wick
Location: Healdsburg, CA
Photographer: Joe Fletcher
Wine Display: W Series Wine Racks, W Series Frames, matte black finish, 315 bottles



THE VALUE of WINE RACKS

the VintageView design effect

HOSPITALITY

91% of restaurants with a visible wine display met/exceed wine revenue (VintageView survey)

Wine is an integral part of Top Cut's design. Our highest valued bottles are held in their own display case right behind the host stand. Wine makes the very first impression. George Paxos, owner, Top Cut (Center Valley, PA)



RETAIL

You need to be unique because you're not going to be everything to everybody. You need to go with higher end [racks], a smaller footprint, and try to meet the local needs. Allen Palmer, retail designer, Hollen Industries



HOME

31% of homes with wine displays sell above ask *Zillow.com
31% of high earning homeowners rate a wine display as the top amenity *realtor.com



Top Cut
Center Valley, PA

RESOURCES

CUSTOM | DESIGN SERVICES
SPECS | TRAINING | INSTALL

CUSTOM OPTIONS

VintageView focuses on beautiful, modular products that are designed to create beautiful custom wine rooms. The flexibility offered by our different heights, depths, and colors is sometimes not quite enough to meet the exact project needs.

When that is the case, we have you covered with a variety of custom services.



Custom Metal Fabrication

- Ladder Style Supports
- Diamond Bins
- Chevron-Style Shelves
- Anything else you can dream up

Cut to Fit

- W Series Wine Racks (height)
- Evolution Wine Wall (height)
- Evolution Wine Wall/Wine Tower /Wine Rods (width)
- Evolution Shelf (width)

Custom Evolution Wine Tower Panels

- Acrylic sides can be customized with ease
- Depth: 1 to 12 bottles
- Height: Up to 120"
- Configuration: Mix bottle sizes and layouts
- Lights: Channels for your LEDs

Custom Colors

If it's on the color wheel, we can likely make it a reality with custom powder coating.

Change the finish on W Series, Evolution, Case & Crate, and IDR products.



RACKS LOOK GREAT IN PERSON

Check out our wine storage systems in person by:

- Visiting VintageView Design Center in Denver (expected re-opening mid 2021)
- Taking the online Virtual Tour of the Design Center
- Visiting one of our Showroom Partners
- Supporting a local restaurant with our racks



DESIGN YOU CAN TRUST

Regardless if you know how you want the room to look or haven't a clue on what to put on the wall, our design team brings decades of experience to help you figure out which products should go where.

COMPLIMENTARY 2D Design

All we need is a few days, accurate measurements, and project goals, and we'll create a 2D layout for your wine room.

VIBRANT 3D Design

For larger projects needing a more realistic showcase of the racking, we produce 3D room drawings that look pretty darn close to a photo. Fees may apply; limited availability.

DESIGN RESOURCES

If your team has inhouse designers, we offer CAD blocks and Revit families for all of our products. Download and get creative.

More at...[VINTAGEVIEW.COM/2021](https://www.vintageview.com/2021)

TRAINING

We never want you caught unprepared heading into a client meeting to discuss a wine cellar project. Join **VintageView** each month for a variety of online events that will teach you tons about our product, wine cellars, and more.



Credit (CEU) Online

Our “6 Steps to Designing a Modern Wine Cellar” is a 60-minute course, accredited by both the American Institute of Architects and the International Design Continuing Education Council. *Offered monthly.*

WEBINARS

Our 30-minute courses cover:

- product knowledge
- design trends
- marketing, sales, and more.

Offered monthly.

BUILT FOR INSTALLING

We’ve long known our products are simple to install for most DIYers. Yet, there are some nuances that give folks pause. That’s why we’ve teamed up with the **BILT** app to provide interactive 3D installation guides direct to your mobile or tablet device.

Whether you are a seasoned GC or a novice DIYer, this handy tool will turn you into a **wine rack hero** and have you confidently aligning and installing VintageView wine racks.

We also provide detailed specification sheets, written instructions, and video guides to ensure you have every resource to understand how our products work and where they fit.

Assembly



× 1

PERSON

30

MINS

20

STEPS

POWERED BY **BILT INTELLIGENT INSTRUCTIONS**®

SCAN FOR **BILT** 3D INSTRUCTIONS



POWERED BY **BILT INTELLIGENT INSTRUCTIONS**®

BUILT FOR A LIFETIME

We value quality as much as the design of our products. That is why we back every product we produce with a lifetime warranty against defects. Whether you are specifying VintageView for a client or installing them in your home, know that we stand behind the storage systems that will hold valuable vintages for decades.

More at ...
[VINTAGEVIEW.COM/2021](https://www.vintageview.com/2021)



W SERIES



Single
h: 4.5"
w: 13"
d: 5.25"
capacity: 1



Minimal
(single-bottle depth)
h: 4", 1', 2', 3', 4'
w: 13"
d: 5.25"
capacity: 1-12



Balanced
(double-bottle depth)
h: 4", 1', 2', 3', 4'
w: 13"
d: 8.5"
capacity: 2-24



Max Capacity
(triple-bottle depth)
h: 4", 1', 2', 3', 4'
w: 13"
d: 12"
capacity: 3-36



Magnum Minimal
(single-bottle depth)
h: 45"
w: 15"
d: 5.25"
capacity: 9

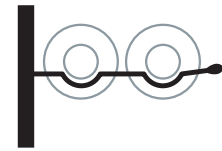

Magnum Balanced
(double-bottle depth)
h: 45"
w: 15"
d: 10"
capacity: 18



Big Bottle ≤6L
(single-bottle depth)
h: 45"
w: 18"+
d: 8"
capacity: 4



Stemware Rack
h: 4"
w: 13"
d: 6.5" | 9.5" | 13"
glasses: 2 | 4 | 6



Presentation Row
h: 6"
w: 13" | 39"
d: 13"
capacity: 3 | 9



Shelf
h: 4 1/8"
w: 13"
d: 8.5" | 12"

Specs include room for your wine bottles | These products are subject to one or more US patents.

Finishes



Matte Black



Brushed Nickel



Chrome Luxe



Golden Bronze Luxe



Gunmetal Luxe

CREATE a floating WINE WALL

RESOURCES | SPECS



1 Cut W Series Frame (on site) to fit ceiling height.



2 Pick W Series racking*.



3 Add W Series racking to one or both sides.



4 Add a backer bar to one-sided displays.

Standard Frames:
10'
12'
10' magnum

Custom Frames:
15'
Split bottles
3L+ bottles

Specs ...
Single Sided:
Add Backer Bar and
1.5" to depth of racking

Double sided:
Add 1" to depth of racking

* Patented

Accessories



Shelf



Stemware Rack



Perch



Bottle Retention Strap



Presentation Row



Single

SCAN FOR BILT. 3D INSTRUCTIONS



POWERED BY BILT INTELLIGENT INSTRUCTIONS

VINO SERIES

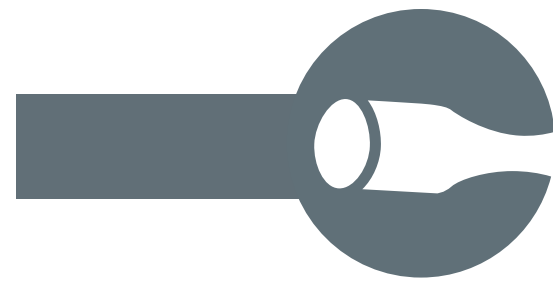

Finishes

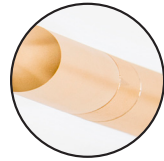

Golden Bronze

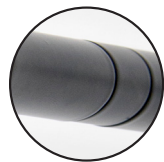

Matte Black

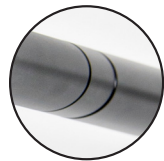

Gloss Black



Gunmetal

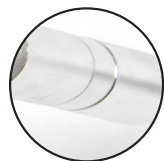

Aluminum

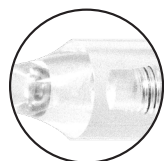

Acrylic

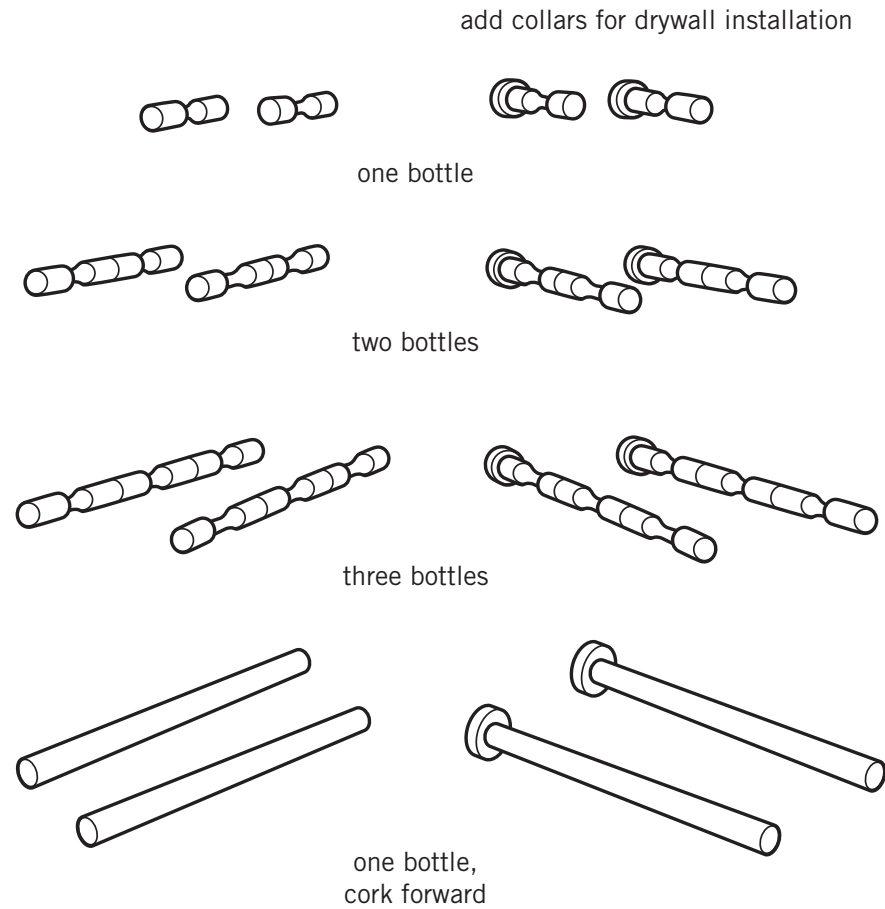

*add 1/2" depth when using collars



Minimal
Standard or Mag bottles
(single-bottle depth)
h: 5" standard/
6" mag
w: 13"/15"
d: *4"
capacity: 1



Balanced
(double-bottle depth)
h: 5"
w: 13"
d: *8"
capacity: 2



Maximum
(triple-bottle depth)
h: 5"
w: 13"
d: *12"
capacity: 3

CREATE a floating WINE WALL

RESOURCES | SPECS

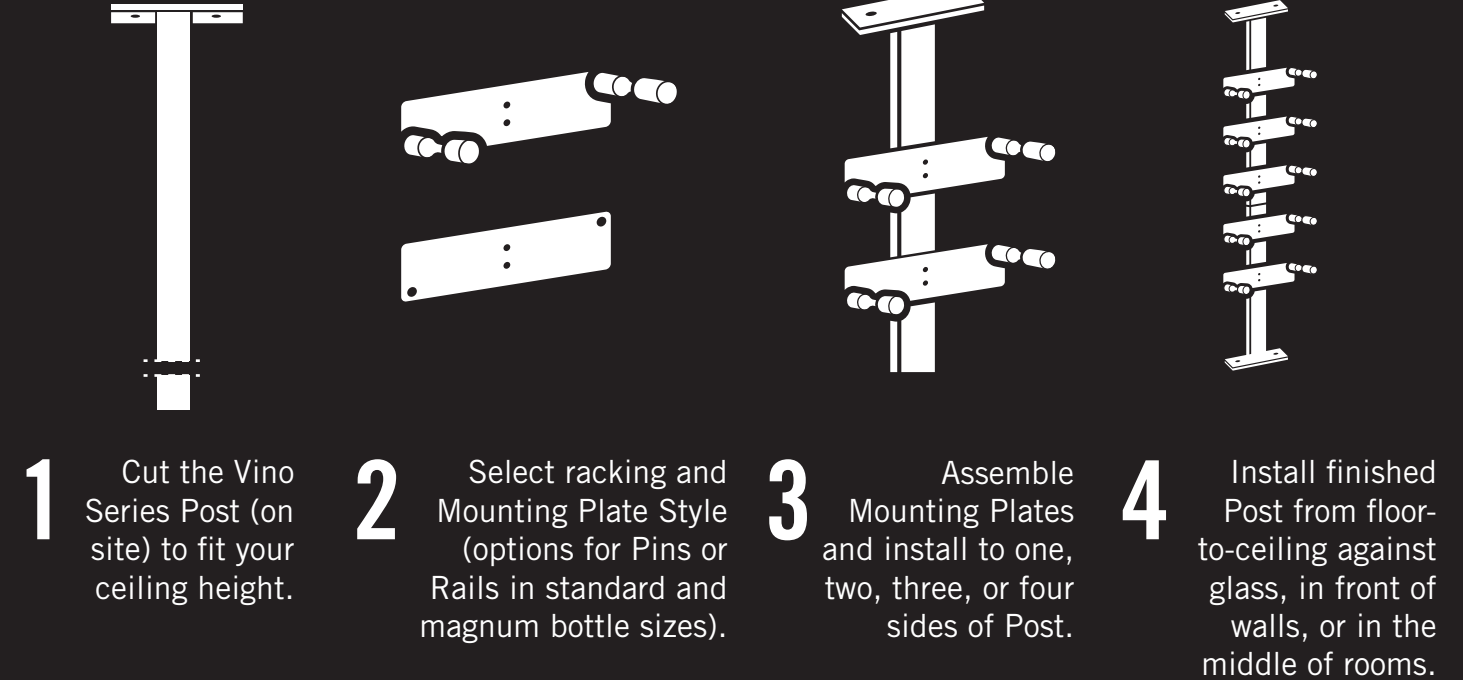

* Patent pending

SCAN FOR BILT: 3D INSTRUCTIONS



POWERED BY BILT INTELLIGENT INSTRUCTIONS®



Magnum Balanced
(double-bottle depth)
h: 6"
w: 14"+
d: *8½"
capacity: 2 (1.5L)



Cork Forward
(single-bottle depth)
h: 5"
w: 3"
d: *13"
capacity: 1

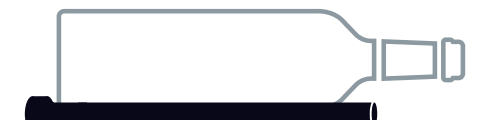

Cork Forward Magnum
(single-bottle depth)
h: 6"
w: 3.5"
d: 15"
capacity: 1

Specs include room for your wine bottles | These products are subject to one or more US patents.

WINE WALL EVOLUTION

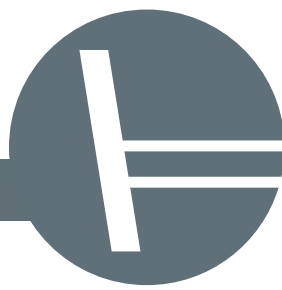

bottle depth options:
single 4 1/8" | double 8 1/8" |
triple 12 1/8"



Presentation Row

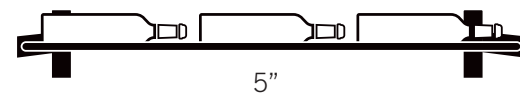

5"

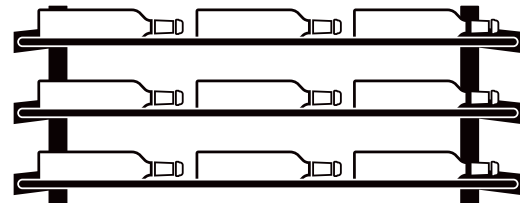

15"

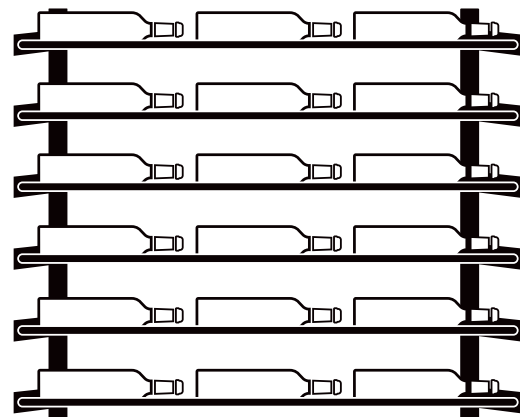

30"

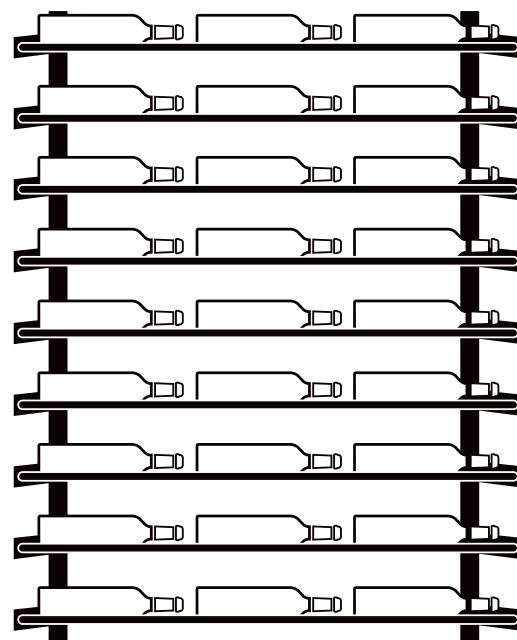

45"

Wine Wall		
Height	Depth	Bottles
5 in	Varies*	3, 6, 9,
15 in	Varies*	9, 18, 27
30 in	Varies*	18, 36, 54
45 in	Varies*	27, 54, 81

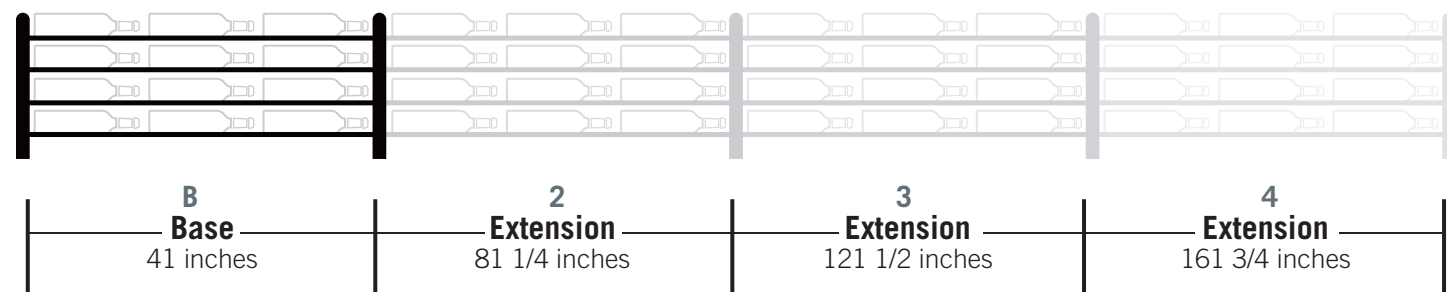

WINE TOWER EVOLUTION

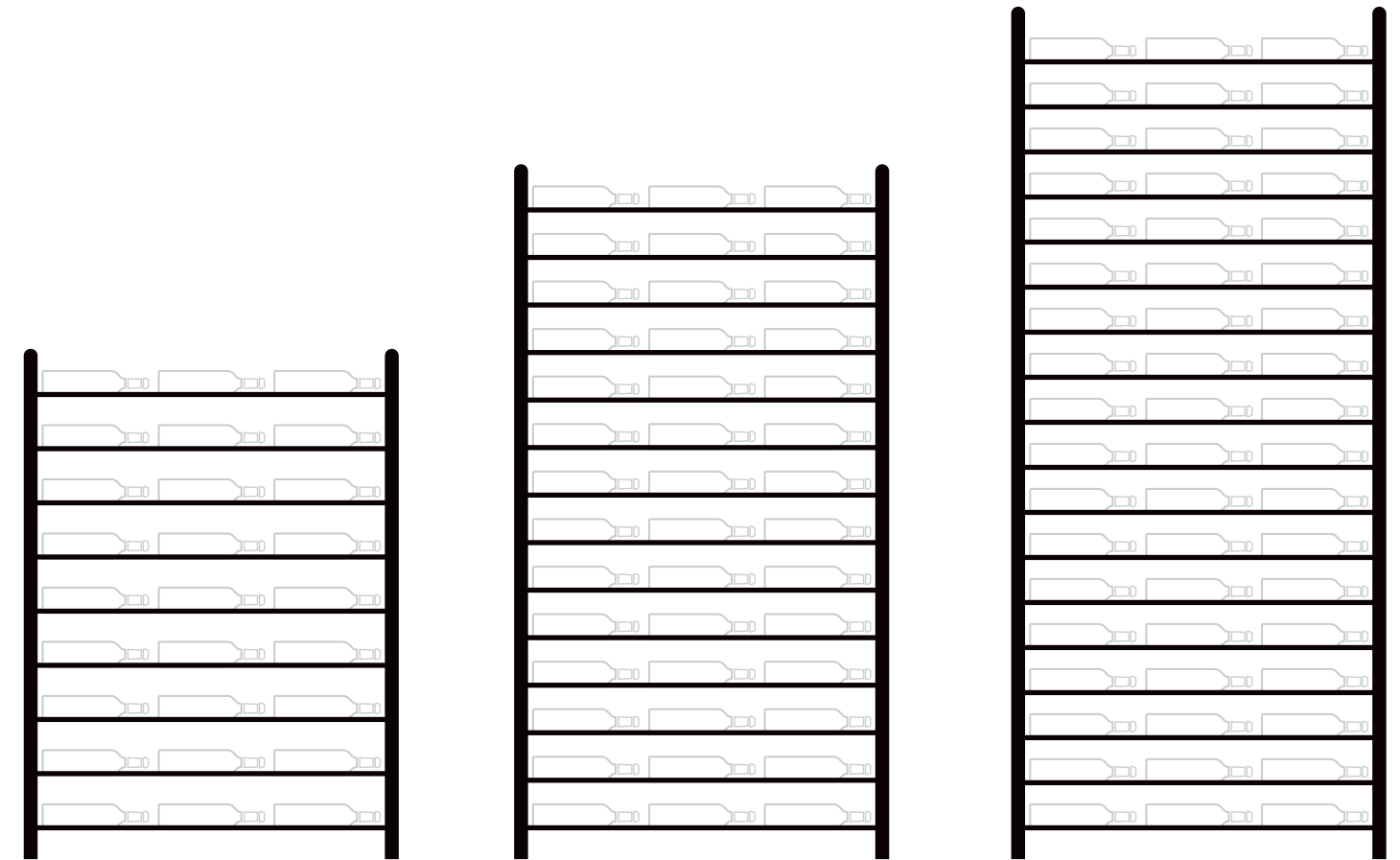

Wine Tower 4

	Width	Columns	Bottles
B	40 1/2 in	3	81
2	80 1/2 in	6	162
3	121 in	9	243
4	160 1/2 in	12	364

Wine Tower 6

	Width	Columns	Bottles
B	40 1/2 in	3	126
2	80 1/2 in	6	252
3	121 in	9	378
4	160 1/2 in	12	504

Wine Tower 8

	Width	Columns	Bottles
B	40 1/2 in	3	162
2	80 1/2 in	6	324
3	121 in	9	506
4	160 1/2 in	12	648

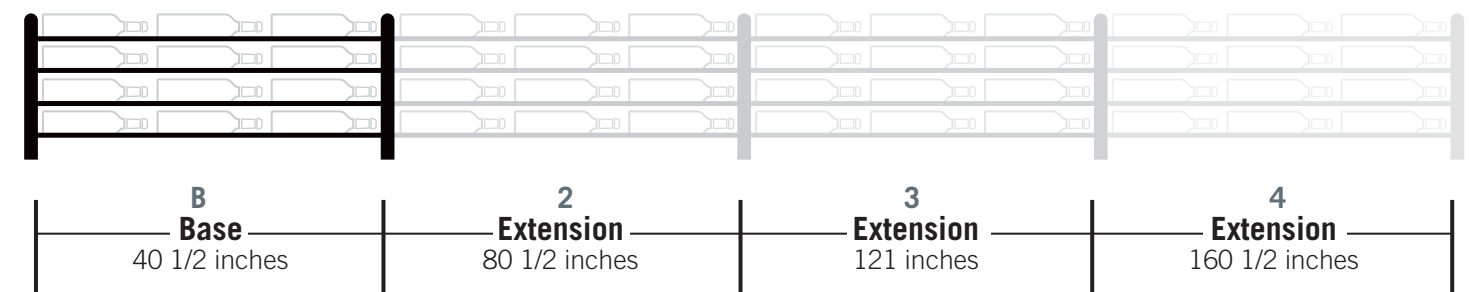

CREATE a floating WINE WALL

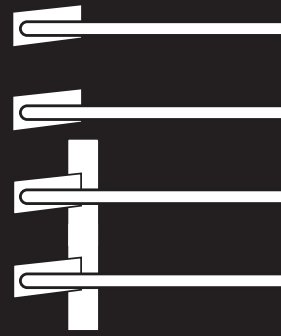

1 Choose either **Low Profile Post** or **Wine Wall Post** style.



2 Cut the Wine Wall Posts* (on site) to fit your ceiling height.

3 Build the **Low Profile Post** or **Wine Wall Post** system.

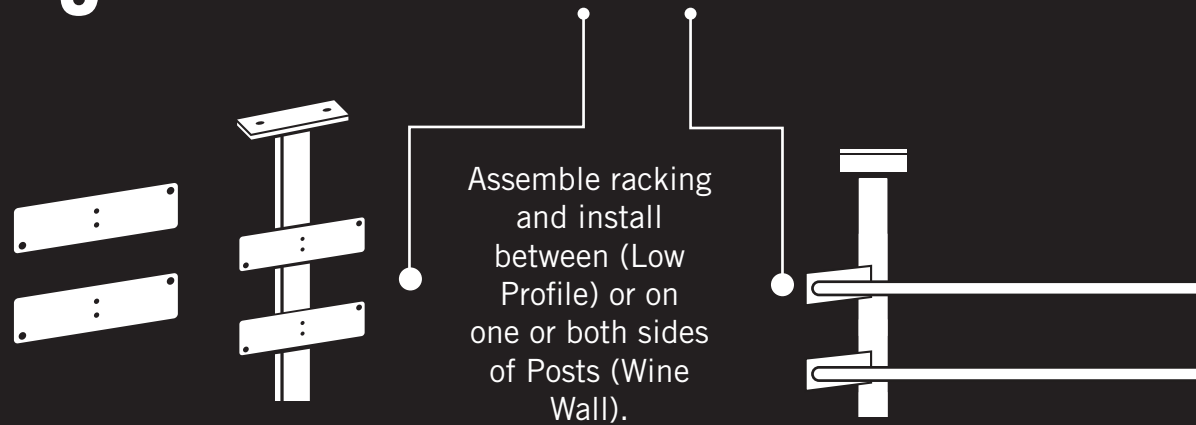

4 Install finished **Low Profile** or **Wine Wall** column against glass or in the middle of rooms.

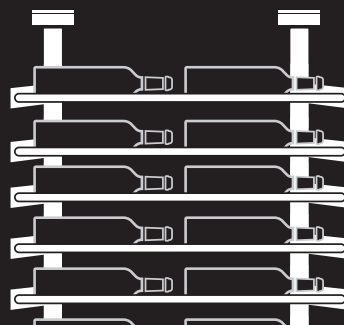

* Patent pending

Finishes



Matte Black/
Chrome

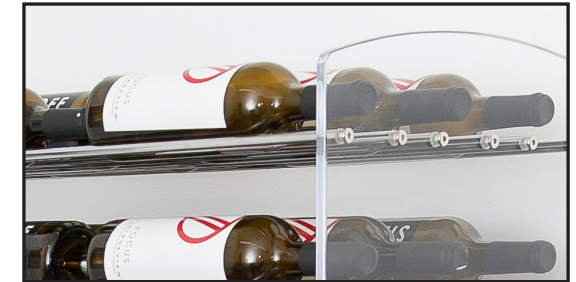

Acrylic/
Chrome



Matte Black/
Golden Bronze



Acrylic/
Golden Bronze



Matte Black/
Matte Black



Acrylic/
Matte Black

CASE & CRATE

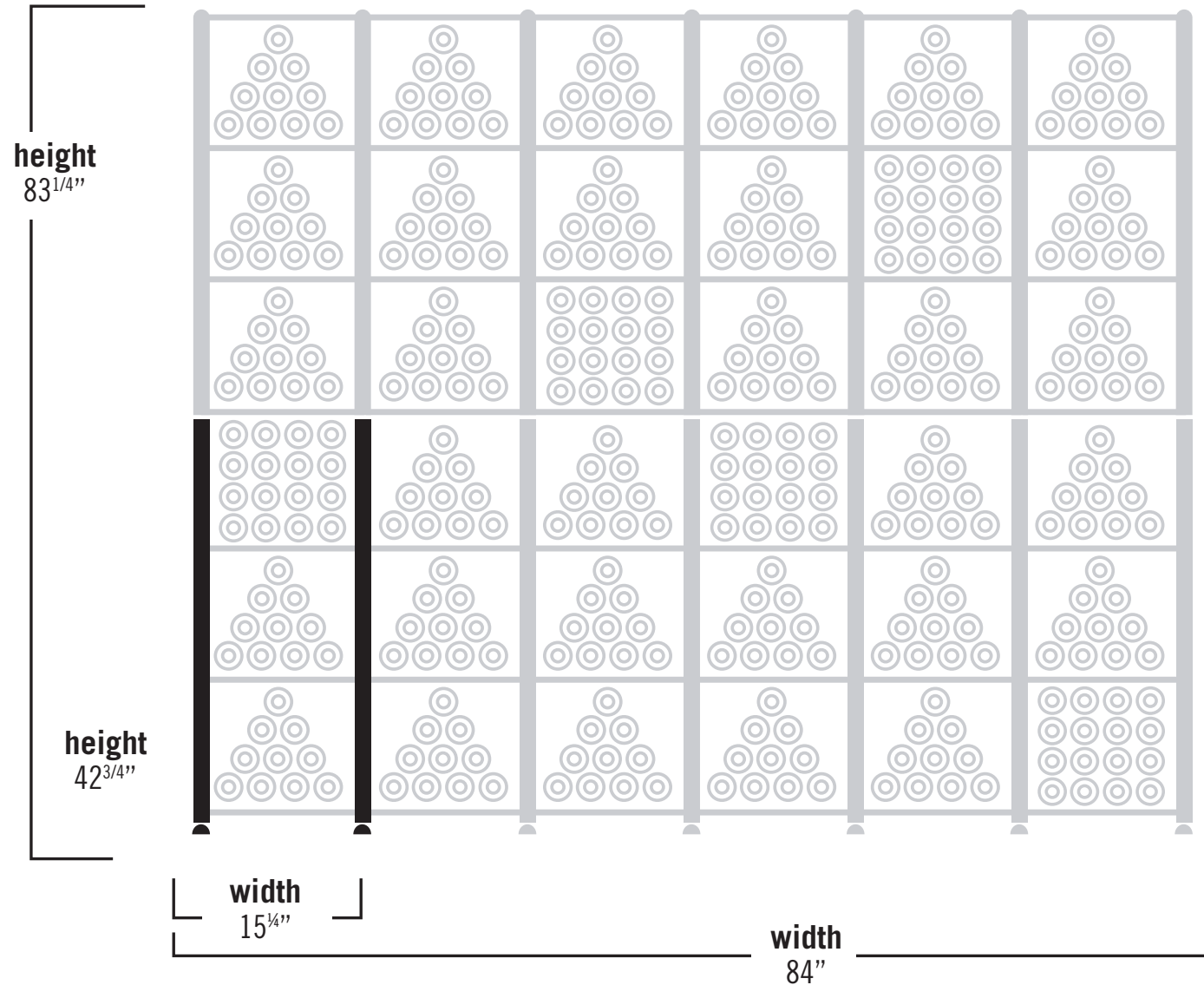
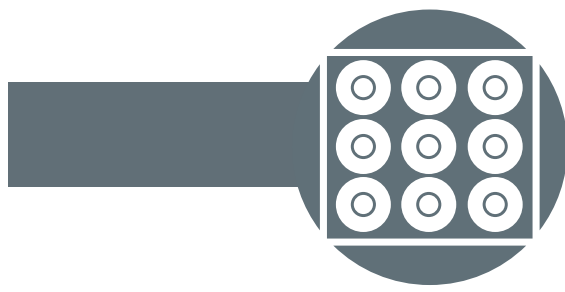

Accessories

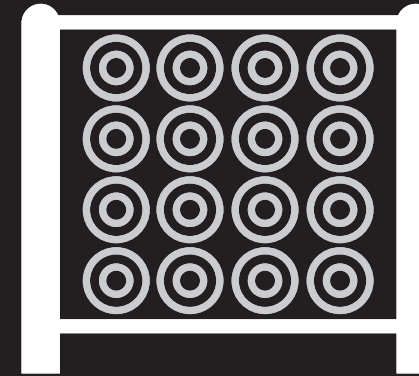

Bin
Open concept, lots of storage.

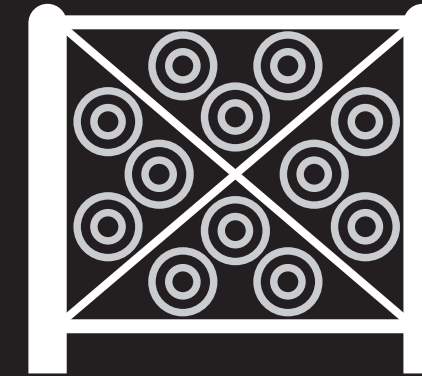

X-Bin Insert
Aesthetic enhancement to any Bin or Locker.



Locker Door
Upgrade any Bin — now or later — with a grated door.

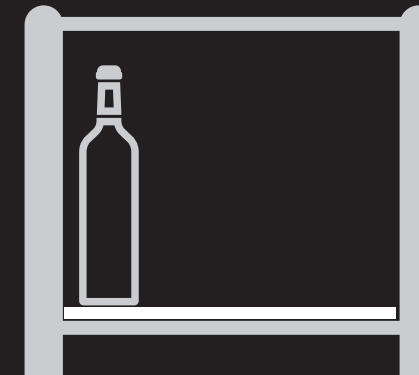

Syrah Shelf
Have a favorite winery? Stand that bottle up to show it off in the middle of any Locker or Bin run.

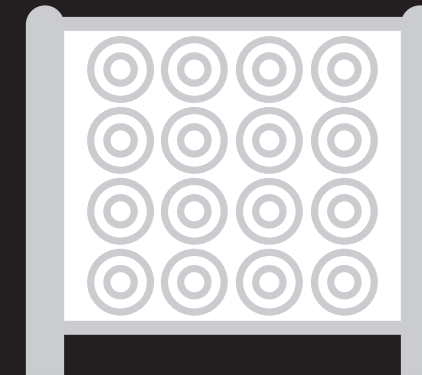

Back Plate
A simple steel sheet that closes off the back of any Bin or Locker. Provides a new aesthetic and further security.

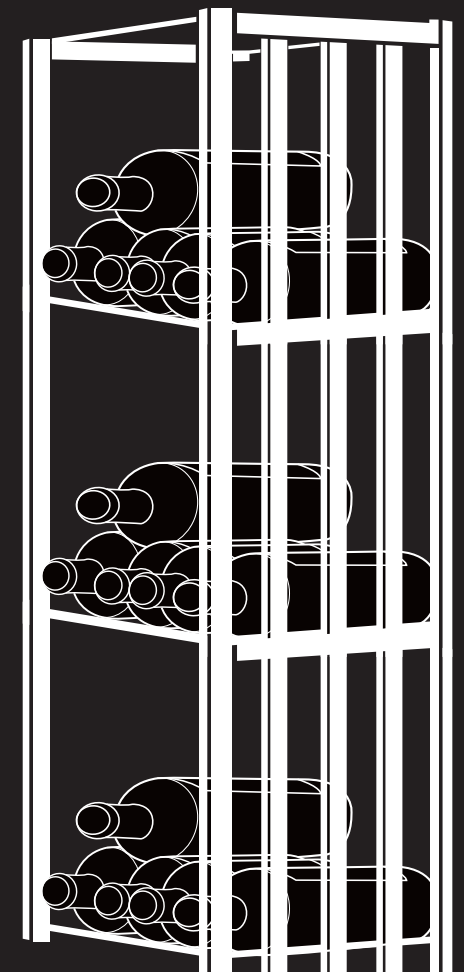

depth 15"

Finishes



Matte Black

DISPLAY RACKS ISLAND

RESOURCES | SPECS

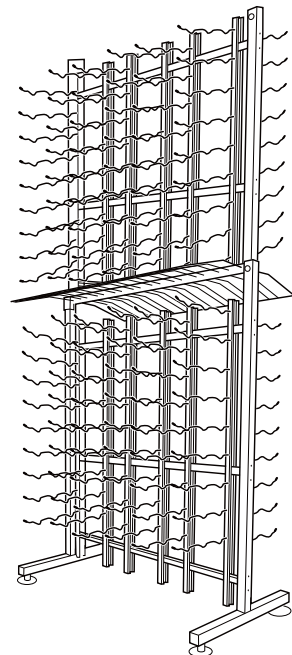
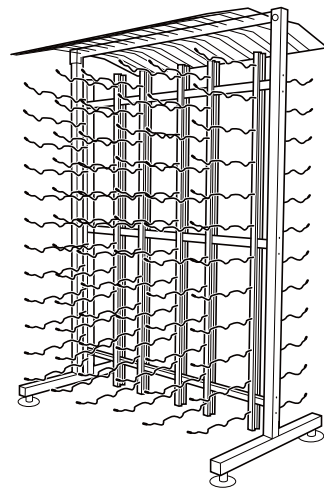
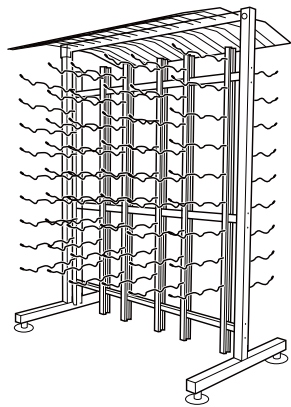

IDR 3 Kits*

IDR 4 Kits*

IDR 7 Kits**

	Width	Columns	Bottles
B	40 1/2 in	3	180
2	79 1/2 in	6	360
3	118 1/2 in	9	540
4	157 1/2 in	12	720

	Width	Columns	Bottles
B	40 1/2 in	3	234
2	79 1/2 in	6	468
3	118 1/2 in	9	702
4	157 1/2 in	12	936

	Width	Columns	Bottles
B	40 1/2 in	3	288
2	79 1/2 in	6	576
3	118 1/2 in	9	864
4	157 1/2 in	12	1152

* IDR 3s and 4s available in one-sided, half units ** IDR7s available in a 378-bottle XL configuration

Modular Extensions Available Extension kits allow for modular growth of any IDR racking option.

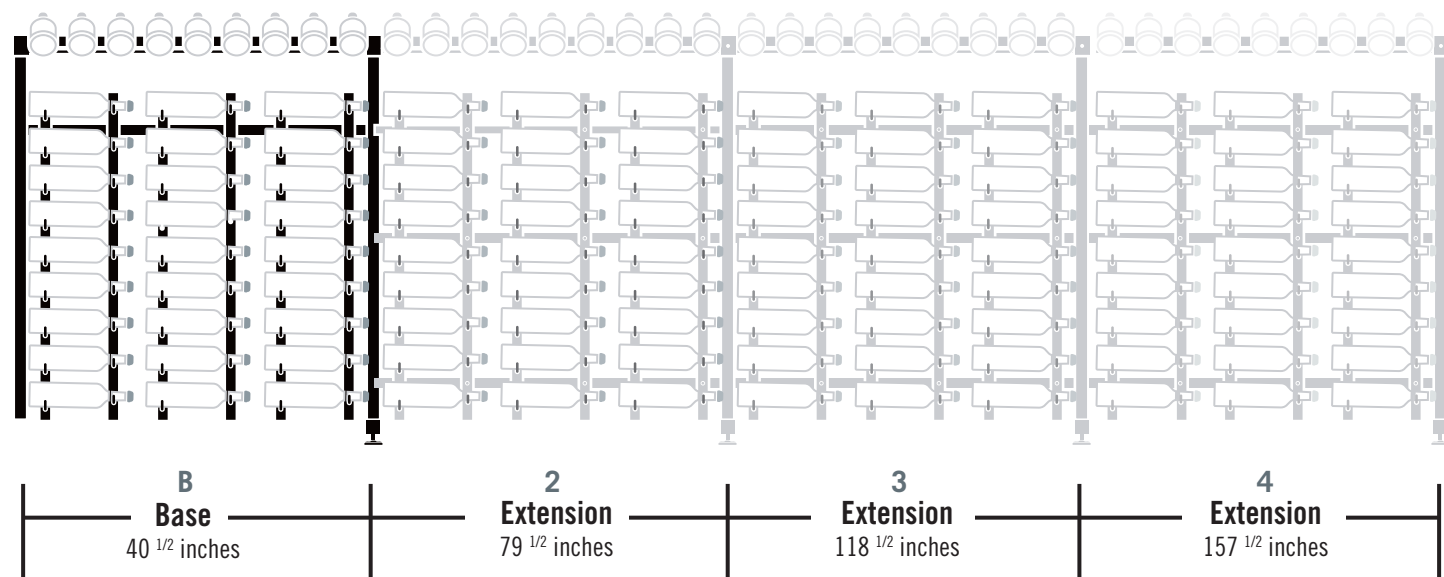

Accessories

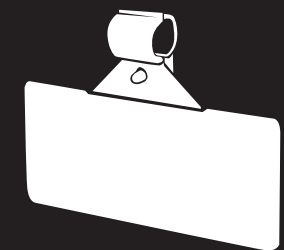
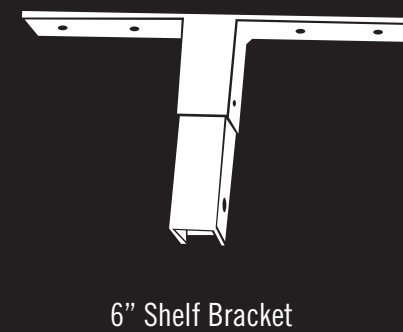

Finishes

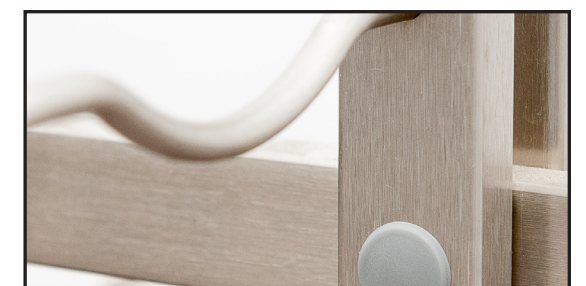

408+

That's the number of times top design and build firms tagged us on Insta on their seriously beautiful wine storage projects. We're honored they specify VintageView — and love us enough to brag about it to the world.

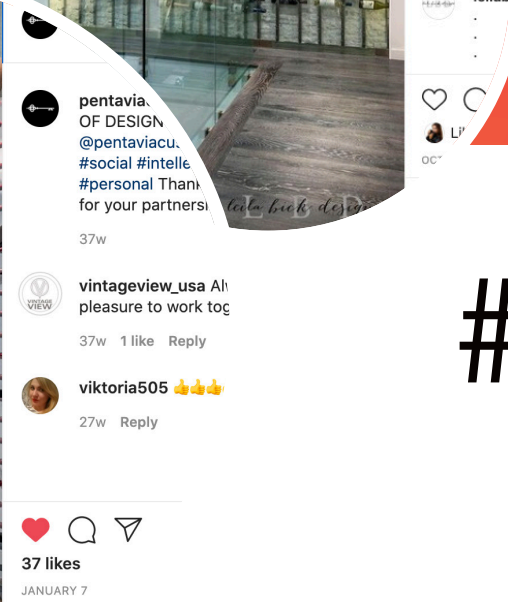
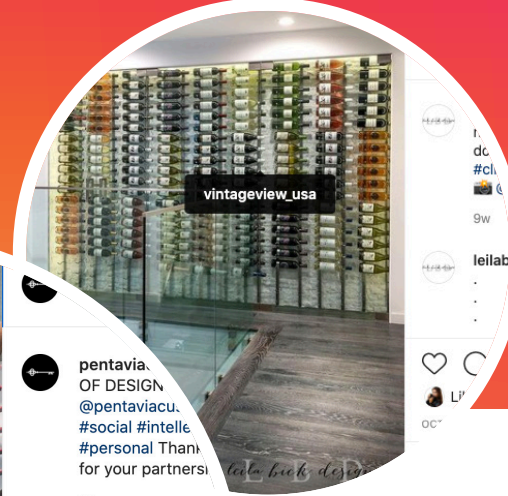
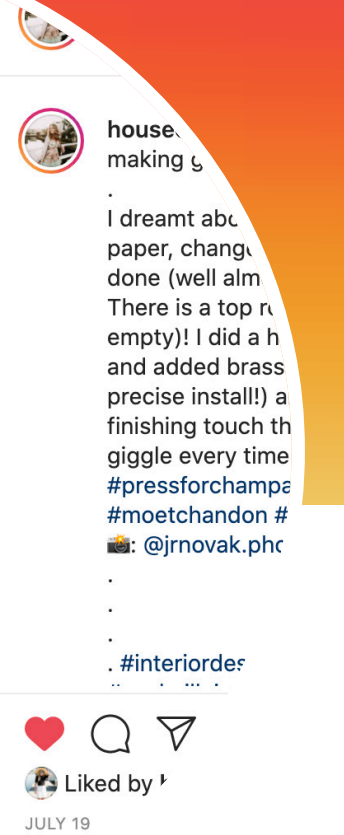
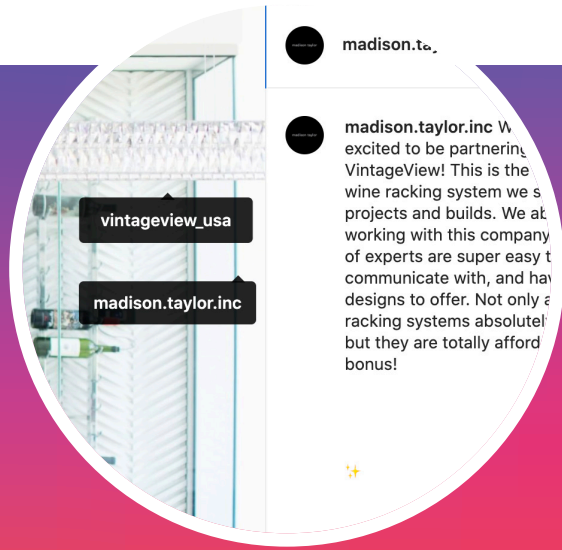
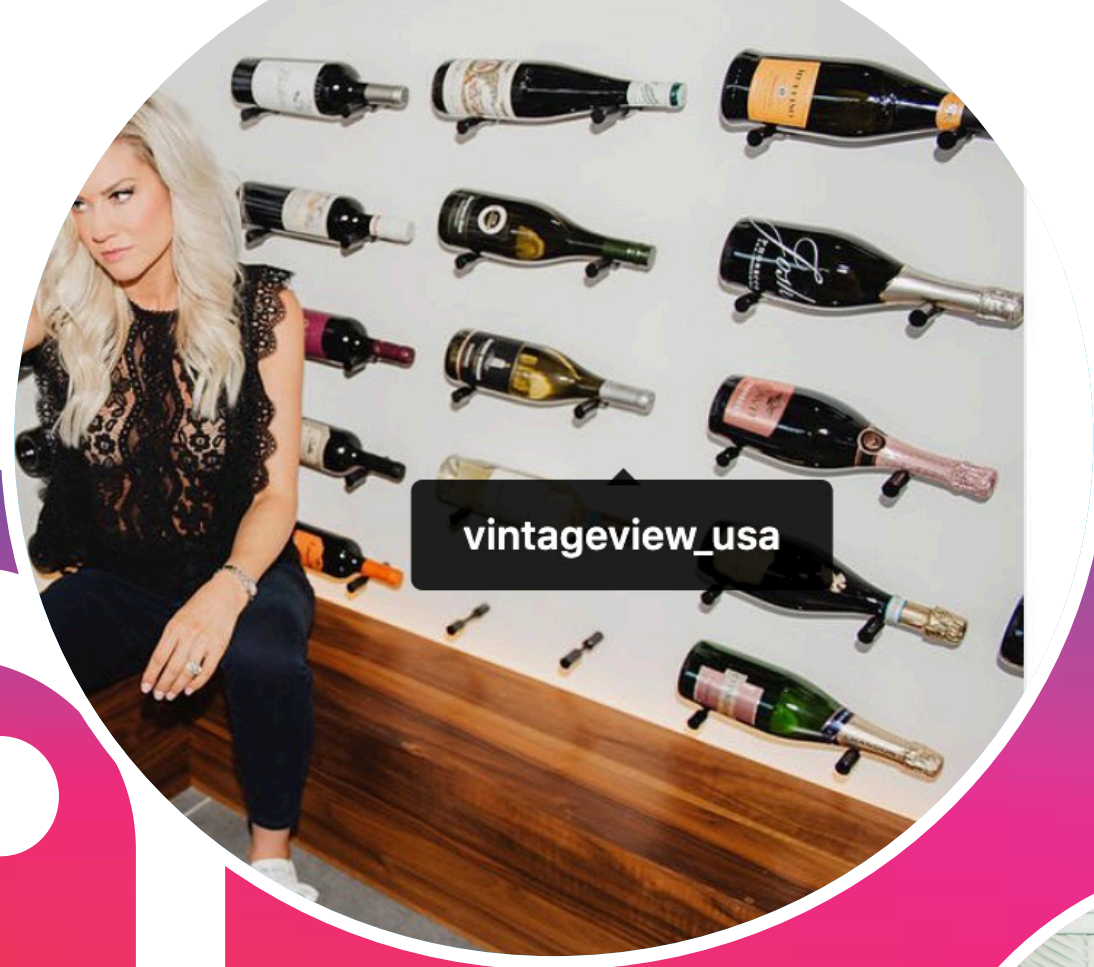

#weloveyoutoo

VINTAGEVIEW.COM/2021



GET IN TOUCH

303-504-9463

VintageView Design Center:
4690 Joliet St., Denver, Co 80239
VINTAGEVIEW.COM/2021